

OIL REMOVAL FILTER

SHAVO
FIRST NAME IN PNEUMATICS

SF51 (G ¼, G ⅜, G ½)

FEATURES

- Shavo's very high efficiency filter for removal of Oil from compressed air.
- Highest purity of compressed air filtration possible.
- Removes solid particles as well as oil contamination beyond 1 part per million by weight i.e. less than 1 mg/m³.
- Use with a pre-filter.
- Specially suited for instrumentation and Air-gauging.



PARAMETERS	SPECIFICATIONS	
Pipe Threads	G 1/4, 3/8, 1/2 Parallel (F)	- Standard
	BSPT. / NPT	- Optional
Element Material	Composite element	
Body Material	Al. Alloy die-cast	
Bowl Material (Orientable)	Transparent Polycarbonate	- Standard
	Al. Alloy Metal with sight glass	- Optional
Maximum Inlet Pressure	with PC Bowl : 10.5 kg/cm ² (150 psig)	
	with Metal Bowl : 17.5 kg/cm ² (250 psig)	
Operating Temperature Range (ambient)	with PC Bowl : -6° C to 50° C (20° F to 120° F)	
	with Metal Bowl : -6° C to 80° C (20° F to 175° F)	
Recommended flow (at an inlet pressure of 7 kg/cm ²)	standard element	12.0 dm ³ /s (25 scfm)
	extended element	25.0 dm ³ /s (53 scfm)
Particle Removal	upto 0.01 micron	
Maximum Oil Removal content	upto 0.01 ppm	
Drain	Standard	- Manual
	Optional	- Automatic
Bowl Guard	Optional	
Mounting Bracket	Optional	
Ball Valve	Integrated exhaust type Shut-off valve for instant isolation available as optional.	
Note : Recommended	Use Pre-Filter with 5 micron.	

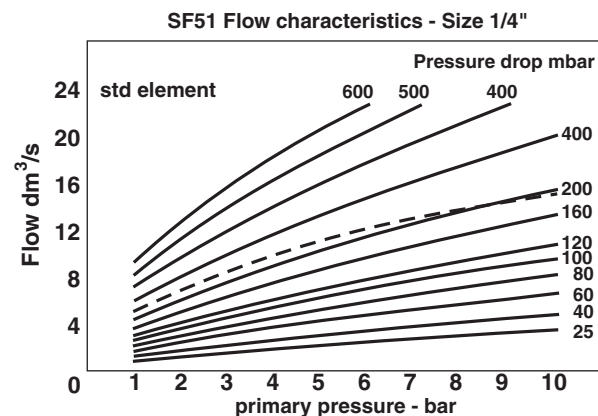
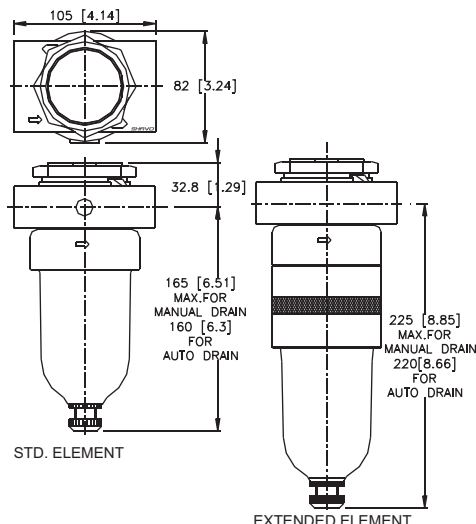

* Technical know-how, design and drawings originally from C.A. Norgren Co. USA

SHAVO

Mumbai, India.

Tel. : 022-2760 4700

Fax : 022-2760 4790

A017/1
0702

OIL REMOVAL FILTER

SHAVO
FIRST NAME IN PNEUMATICS

SF51 (G 1/4, G 3/8, G 1/2)

Size	Flow (dm ³ /s)	Element	Drain	Bowl	Model
G 1/4	12.0 dm ³ /sec (Standard)	Composite Element	Auto Manual	Transparent Transparent	SF51-200-AOTC SF51-200-MOTC
G 3/8	25.0 dm ³ /sec (Extended)	Composite Element	Auto Manual	Transparent Transparent	SF51-320-AOTC SF51-320-MOTC

Option Selector

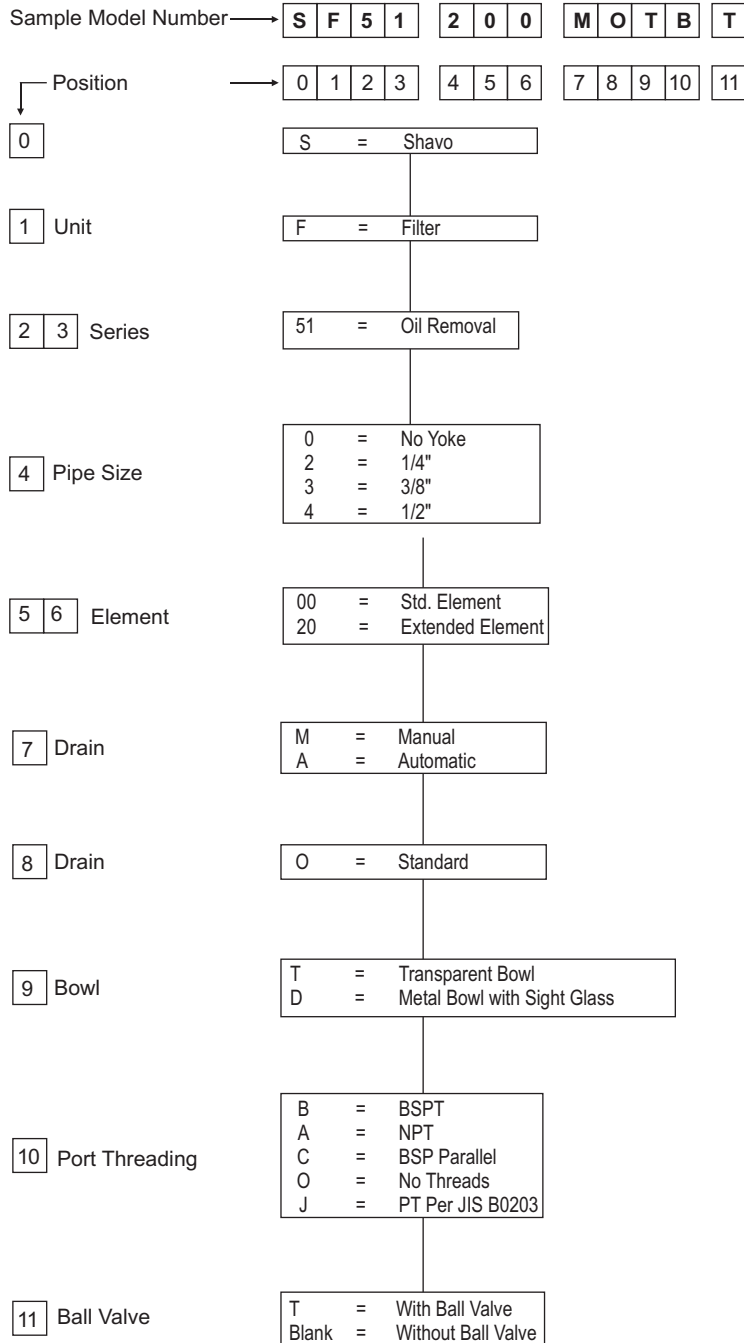

* Technical know-how, design and drawings originally from C.A. Norgren Co. USA

SHAVO

Mumbai, India.

Tel. : 022-2760 4700

Fax : 022-2760 4790

A017/2
0702